

Horizontal Grill mod GHPI **F5/1450**

Dimensions:

1450mm (w) x 850mm (h) x 550mm (p)

Weight: 205 kg

Thermal Flow: 30,80 kw

Type: A

Category: II_{2H3+}

Voltage: 230 V

Electric Power: 44 w

Butane gas

Pressure - 28-30 mbar

Consumption - 2,5 kg/h

Propane gas

Pressure - 37 mbar

Consumption - 2,5 kg/h

Natural gas

Pressure - 20 mbar

Consumption - 3,3 m³/h



Scraper

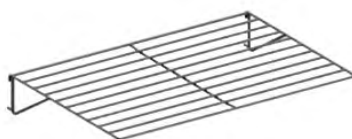

GRE.F2.P71
extra grid



GRE.F5.P70
support for grids

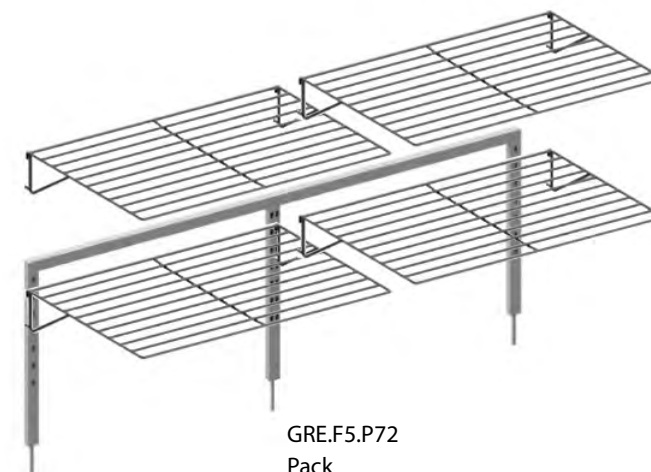

GRE.F5.P72
Pack

Horizontal Grill mod GHPI **F5/1450**

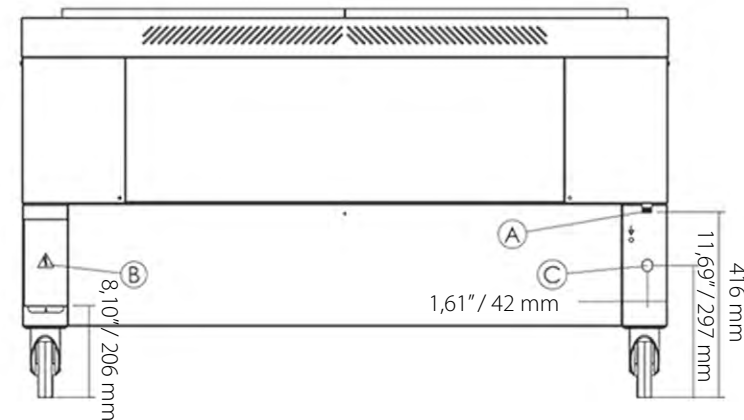
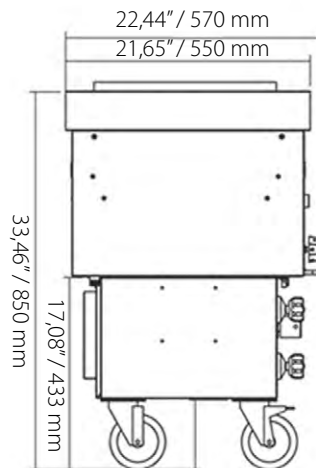
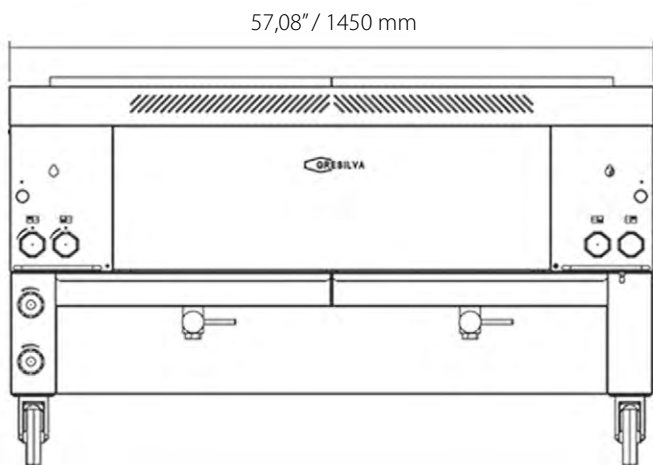

- A - gas inlet 1/2"
- B - power cord output
- C - water inlet 3/4"

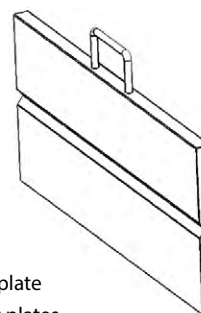
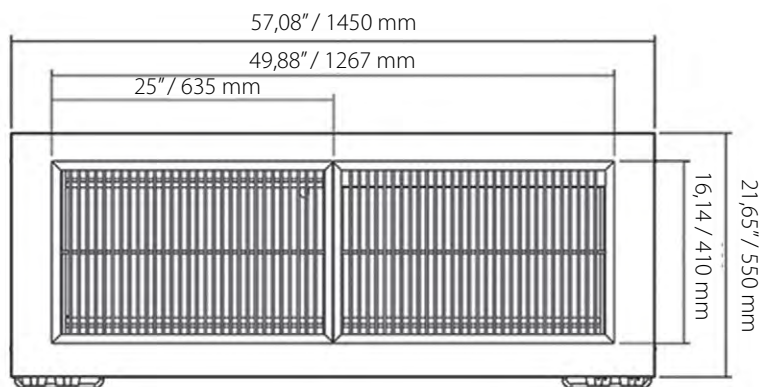

Protective plate
for ceramic plates

