

Horizontal Grill mod GHPI **F2/750**

Dimensions:

753mm (w) x 850mm (h) x 550mm (p)

Weight: 101 kg

Thermal Flow: 15kw

Type: A

Category: II_{2H3+}

Voltage: 230 V

Electric Power: 0,6 w

Butane gas

Pressure - 28-30 mbar

Consumption - 1,1 kg/h

Propane gas

Pressure - 37 mbar

Consumption - 1,1 kg/h

Natural gas

Pressure - 20 mbar

Consumption - 1,5 m³/h



with Robata system

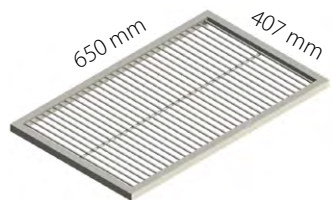

GRE.F2.G10
Rod grid round

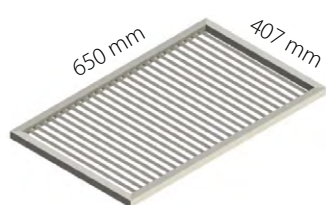

GRE.F2.G20
Square grid

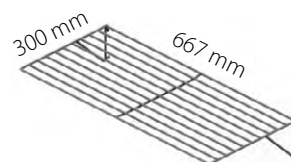

GRE.F2.P71
Extra grid



GRE.F2.P70
Support grids



GRE.F2.P72
Pack

Scraper



Horizontal Grill mod GHPI **F2/750**

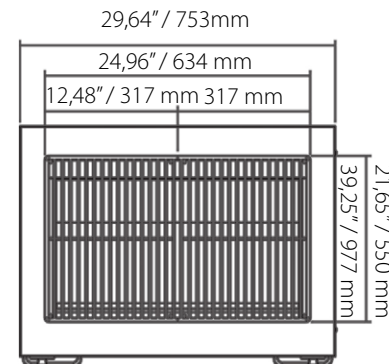
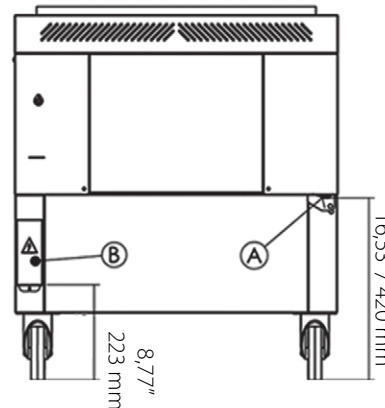
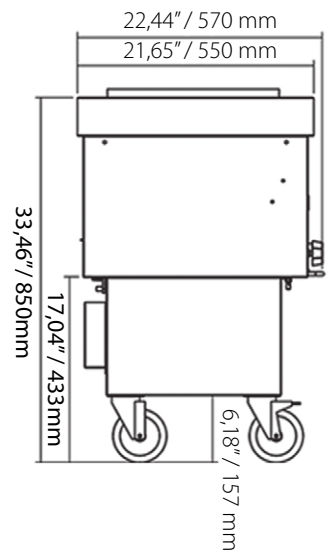
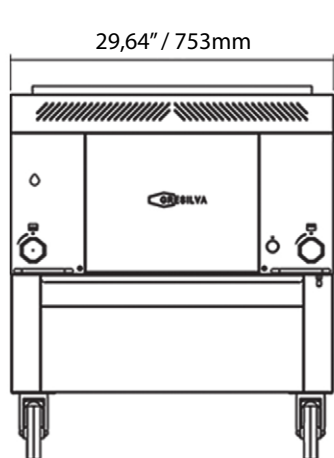

A - gas inlet 1/2"
B - power cord output

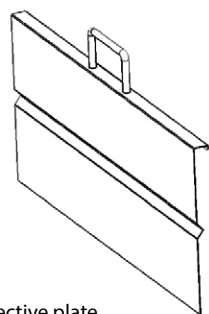
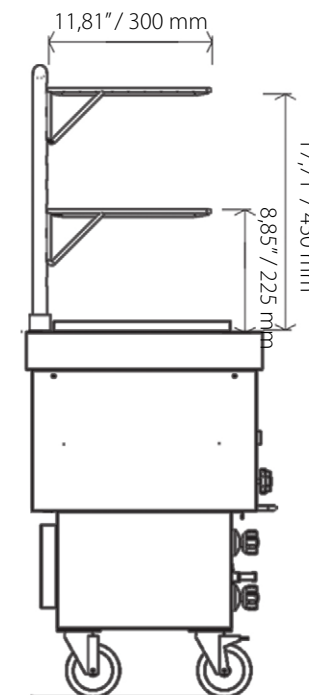

Protective plate
for ceramic plates

