

Horizontal Grill mod GHPI **C2/6**

Dimensions:

29,52" (w) x 30,24" (p) x 33,48" (h)

Weight: 145 kg

Thermal Flow: 17 kw

Type: A

Category: II_{2H3+}

Butane gas

Pressure - 28-30 mbar

Consumption - 1,3 kg/h

Propane gas

Pressure - 37 mbar

Consumption - 1,3 kg/h

Natural gas

Pressure - 20 mbar

Consumption - 1,8 m³/h

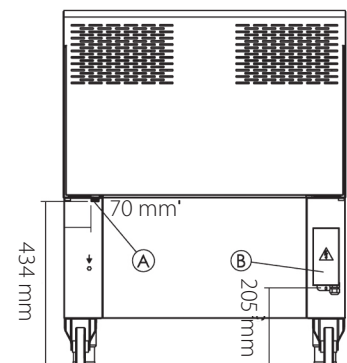
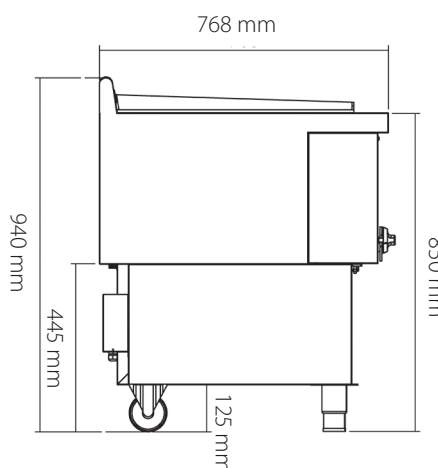
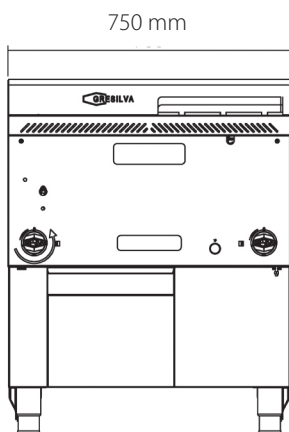
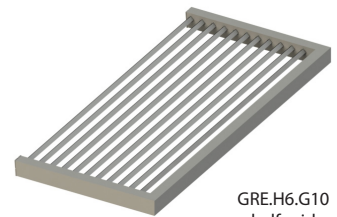

A - gas inlet 1/2"

B - power cord output

